



LAUNDRY EQUIPMENT



TBS BATCH WASHER SYSTEM

ST-100 BATCH DRYER





EXCELLENT OUTPUT

The ST-100 batch dryer is a machine designed for the complete separating, conditioning, and drying of laundry and textile products. A powerful heating system obtains an excellent drying process, having an optimal ratio of circulated air and extracted humidity along with high output and truly low energy consumption.

STURDY AND SIMPLE, GUARANTEED MAXIMUM DURABILITY

The simplicity of its design and the sturdiness of its construction makes for maximum durability with low maintenance.

The chassis is constructed with steel sides finished with high resistant epoxy paint. All the materials which come in contact with the laundry are made of AISI 304 stainless steel.

The large robust drum is supported by a set of guide wheels which give it a precise and silent operation, allowing for rotation reversals in both directions.

THE SPIROTILT-GIRBAU SYSTEM IS THE ONLY ONE TO UNLOAD WITHOUT TILTING AND WITH THE FAN STOPPED

The objective of any dryer manufacturer has always been to find equilibrium between a good drying process and a good unloading system.

The dryers from other manufacturers which operate with an inclined drum to facilitate unloading have problems during the drying process: The laundry becomes accumulated in one end of the drum and the air flow circulation is not good (Fig. 1). They install gaskets to force the air flow to pass through the laundry, which results in increased maintenance problems.

Other dryer manufacturers maintain the horizontal position of the drum to assure a good drying process, but they use the air flow from the fan to unload the laundry.

This system brings lint into the atmosphere of the laundry area, and triggers the unnecessary cool down of the dryer.

Dryers which incorporate a tilt system require steam connections and flexible steam exhaust. The flexible connections can lead to multiple breakdowns and leaks.

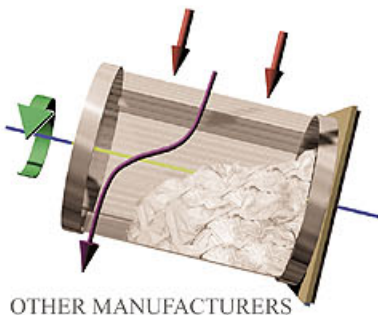

OTHER MANUFACTURERS

Fig.1

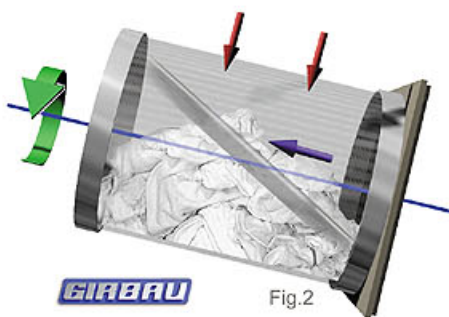

GIRBAU

Fig.2

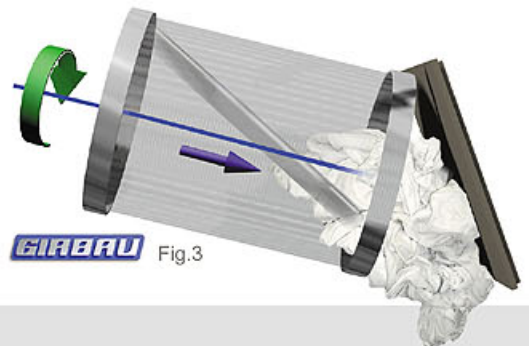

GIRBAU

Fig.3

INCLINED DRUM GIRBAU ST-100 DRYER

The ST-100 dryer has the patented *SPIROTILT-GIRBAU* a revolutionary system which optimizes the drying process and facilitates the unloading of the laundry.

With the slight drum inclination of only 2.5° and the incorporations of inclined blades, the best drying process is obtained along with the best unloading system.

During the drying process, the drum rotation in a clockwise direction. The inclined blades counteract the tendency of the laundry to accumulate in one end of the drum by forcing the laundry to move towards the front part (Fig. 2). The load is balanced along the length of the drum which obtains an optimal drying process without needing gaskets.

In the unloading phase, the drum rotates in a counter clockwise direction. The inclination of the drum and the effect of the blades increase the tendency of the load to move towards the exterior. The unloading is done with the fan stopped and without tilting (Fig. 3). The *SPIROTILT-GIRBAU* system converts the ST-100 dryer into the one which most respects the environment. It avoids the unnecessary operation of the fan, with an important energy savings and without bringing lint into the air.

Working conditions are considerably improved in an environment without lint which brings great benefits to the health of employees.

OPTIMAL ENERGY OUTPUT



HEATING SYSTEMS

The GIRBAU ST-100 batch dryer is available in three heating versions:

- **Steam heating and hot oil heating:**
The steam or hot oil systems of the ST-100 assures high output and excellent efficiency. Their cleaning is simple and easy with very low maintenance.
- **Gas heating:**
The great experience of GIRBAU in gas heated machines has been applied to this version of the ST-100 dryer to optimise its output to the utmost.

The burner system designed by GIRBAU assures a high degree of efficiency. Thanks to its modulating system, the flame self-adjusts to the appropriate heating demand, which makes the energy consumption cost-effective and makes the best advantage of the possibilities of gas.

It includes cool-down and thermostatic control of the drying temperature. In addition, it has a process thermostat and one for maximum safety.

It incorporates an anti-fire water sprinkler (optional in steam and hot oil heating) which will prevent the spread of flames in the hypothetical case of a fire being produced.

- **Dryer-Separator:**
The ST-100D separator is a dryer (without heating system or fan) which does the separating functions of the laundry after exiting a batch washer, in a truly low time.



FLEXIBLE PROGRAMMING

The ST-100 dryer has 16 different drying programs. Each program includes 8 phases. The parameters of each phase can be modified according to the needs of the customer: time; temperature; personalized rotation reverse for clockwise and counter clockwise directions; programming the speed; configuration of all the unloading variables (rotation reverse, total time...), etc.

THE HIGHEST SAFETY LEVEL

The design of the ST-100 dryer ensures conformity with the most demanding world standards in terms of safety. Consequently, it incorporates different safety mechanisms on the loading and unloading doors and in the filter access. It has CE certification, complying with the Machine Safety Directive, the Electromagnetic Compatibility Directive and the Gas Devices Directive.

GREAT VERSATILITY

GIRBAU



A WIDE RANGE OF OPTIONS

■ AUTOMATIC CLEANING OF THE LINT FILTER

The ST-100 batch dryer has an effective automatic cleaning system of the lint filter. The periodic cleaning of the filter is one of the keys in maintaining the high output of the dryer.

When it detects that the filter is saturated, after finishing the unloading cycle (without interrupting any drying process), the automatic filter cleaning process is activated, removing the fibre to the exterior.

■ THERMOSTATIC SPRINKLER

A thermostatic safety sprinkler acts when temperature surpasses the 260°C/ 500°F limit, spraying water in the dryer interior. Before the sprinkler starts, two safety thermostats proceed to stop the machine and disconnect the electrical feed.

■ TEFLON COVERING OF THE DRUM INTERIOR

The Teflon covering of the drum interior avoids that any plastic materials mixed in with the laundry adhere to the drum as a result of the high temperature.

■ COOL-DOWN CYCLE AND TEMPERATURE CONTROL

In the steam and hot oil heating versions, the cool-down is optional.

The opening of a large flap introduces air from the exterior to cool the laundry. The control of the drying temperature (optional in the steam and hot oil versions) is complemented with the previous option. The opening and closing movements of the flap are regulated by thermostat.

■ PEDESTALS ACCORDING TO THE HEIGHT NECESSARY

The ST-100 dryer has five pedestal versions with different heights to assure the best adaptation to the installation space. The tallest height makes the best use of the unloading process.

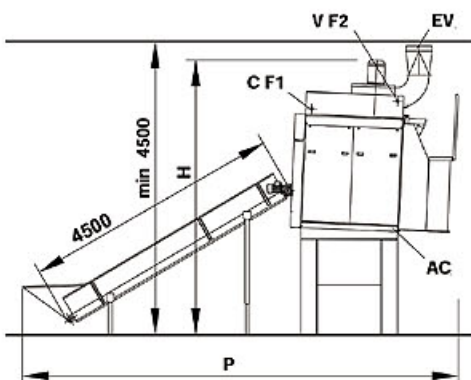
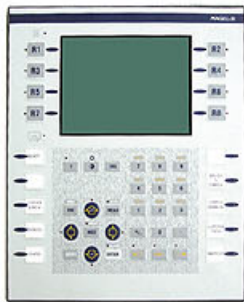

PASS-THROUGH ST-100A DRYER

GIRBAU ST-100A pass-through dryer incorporates an inclined loading conveyor, which permits the machine to function in a totally independent manner.

Once the laundry is loaded on the inclined conveyor, the drying program selected should be validated. When the dryer is prepared, admit the pre-loaded laundry which proceeds to its drying. To finish the drying cycle, the laundry is unloaded automatically into the cart previously located at its unloading point.

A microprocessor control with an integrated keyboard allows the selecting and configuring of 16 drying programs.

The ST-100A is prepared in a way to be easily adapted in the future to an installation with the TBS BATCH WASHER SYSTEM.



GIRBAU, THE GUARANTEE OF A WORLD LEADER

Girbau, S.A. has had a dedicated presence in more than 80 international markets for over 30 years, GIRBAU is a world leader in the manufacturing of industrial laundry equipment for washing and handling fabrics.

GIRBAU's corporate priority is superior support and total customer and user satisfaction, possible by two fundamental priorities:

The superior quality of all the products, are distinguished in the market by design, quality, efficiency, reliability, and constant technological improvement.

The most complete and personalised service, consisting of:
Sales Engineering Department capable of developing personalised Laundry Room drawings and specifications to ensure optimum productivity and results.

Service department, provides responsive total after sale training and support.

Worldwide Distributor Network, capable of providing superior pre-sale and post sale support to ensure complete customer satisfaction.

GIRBAU, QUALITY AND SAFETY CERTIFIED

Girbau products incorporate the most technically advanced improvements in quality and safety, enabling them to carry the CE, GS, WRAS, LGAI (Europe), CSA & ETL (USA) certifications.

Girbau incorporates ISO-9001 Quality Certification since June 1996, validated in January 2000, and an Environmental Management System with ISO-14001 Certification since February 2001 issued by TÜV Rheinland.

Girbau's R&D department uses the most advanced technology, such as calculation by finite element method, strain gauge testing and accelerated reliability tests, thus improving and extending the life of the machine.



